



OZ Optics

www.ozoptics.com

219 Westbrook Rd, Ottawa, ON, Canada, K0A 1L0 Toll Free: 1-800-361-5415 Tel:(613) 831-0981 Fax:(613) 836-5089 E-mail: sales@ozoptics.com

POLARIZERS – FIBER OPTIC

Features

- Rugged & compact housing
- SM, MM, PM and fiber combinations available
- Miniature sizes available
- Wide range of available wavelengths: 400-2050 nm
- High extinction ratio up to 50 dB
- Low loss
- Low back reflection
- Low cost

Applications

- Fiber amplifiers
- System polarization extinction ratio conditioning
- Measuring polarization extinction ratio
- Sensors
- Integrated optics
- Interferometric sensors

Product Description

Fiber Optic Polarizers are designed to polarize the output from a light source or fiber and launch it into an output fiber. These polarizers typically consist of input and output collimators with a plate polarizer in between. Broadband polarizers are used, so the power extinction ratio is maintained for up to several hundreds of nanometers. The same polarizer, for example, may be used for 1300 nm to 1600 nm. The power extinction ratio is the ratio between maximum and minimum output power as the input polarization state is changed. This is different from the output polarization extinction ratio, which is a measure of the ratio between the power in the two axes of polarization maintaining fiber. This value is dependent upon the extinction ratio of the polarizer, the alignment of the output fiber axes to the polarizer and the extinction ratio of the output fiber. When an output extinction ratio is specified, it is the polarization extinction ratio. This value is only applicable when the output fiber is polarization maintaining fiber. The power extinction ratio will always equal or exceed the polarization extinction ratio.

OZ Optics offers fiber optic polarizers in three sizes. The 5.5 mm diameter miniature size is for OEM applications and the smallest size (4 mm diameter) is for low cost systems where reduced output extinction ratio is acceptable. The 20 mm diameter size is best suited for non-telecom wavelengths and custom designs. The larger size is also well suited for high power applications. Polarizers capable of transmitting several Watts of power have been made with this technique.



FOP-41
Inline Miniature (3 mm OD) Pigtail Polarizer



FOP-21
Inline Miniature (5.5 mm OD) Pigtail Polarizer



FOP-31
Low Cost Miniature (4 mm OD) Polarizer



FOP-11
Pigtail Style Polarizer for Non- Telecom Wavelengths

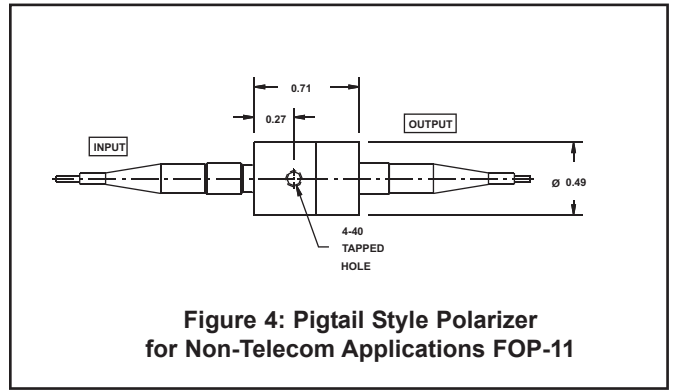
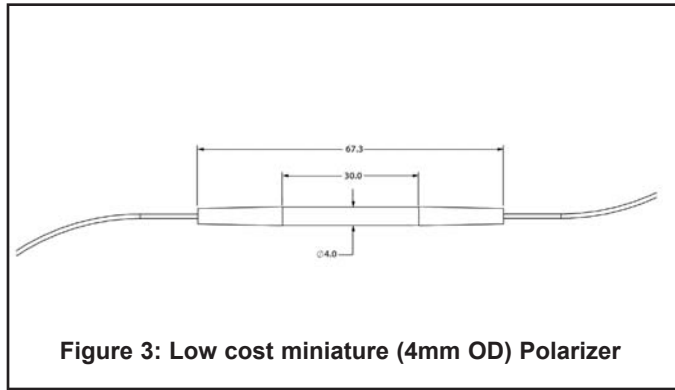
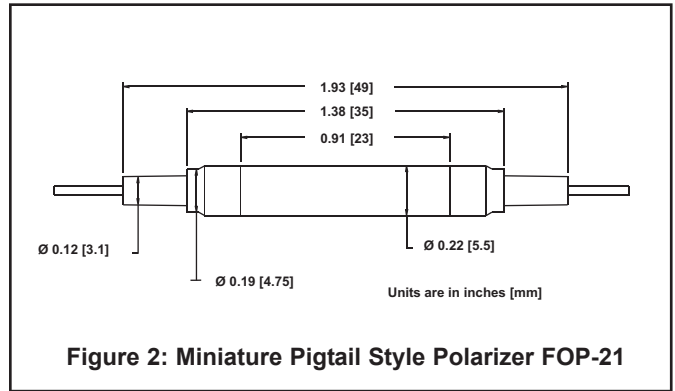
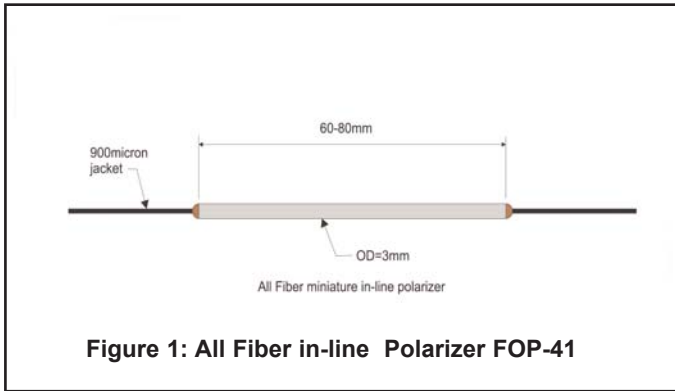

Standard Product Specifications

Parameter	Units	Condition	Value			
			FOP-11	FOP-21	FOP-31	FOP-41
Polarizer Model			FOP-11	FOP-21	FOP-31	FOP-41
Available Wavelengths	nm		400-2050	1280-2050		
Polarization Extinction Ratio	dB	600-1064 nm ¹	20	Not Available		
		1300-1550 nm ¹	20 or 30	20 or 30	20	30
Return Losses	dB	600-1064 nm ¹	40	Not Available		
		1300-1550 nm ¹	40 or 60	40 or 60	40	70
Insertion Losses (Typical)	dB	600-1064 nm ¹	0.8	Not Available		
		1300-1550 nm ¹	0.7	0.8	1.0	0.5
Insertion Losses (Maximum)	dB	600-1064 nm ¹	1.2	Not Available		
		1300-1550 nm ¹	1.0	0.9	1.5	1.0
Insertion Losses (60dB return loss Option)	dB	1300-1550 nm ¹	0.7 max	0.6 max	Not Available	

¹ Specifications are for a specific operating wavelength, to be identified when ordering.

Questionnaire

1. What is your operating wavelength?
2. What type of fiber do you have for your input?
3. What type of fiber do you need on the output?
4. What is the maximum acceptable return loss for your setup?
5. What is the minimum acceptable output extinction ratio?
6. Is size a critical concern?
7. Is cost a critical concern?
8. How long should the fibers be, and what type of cabling do you prefer?
9. Do you require connectors on the fiber ends? If yes, what type?
10. How much optical power is being transmitted through your system?

Standard Parts

Polarizers for 600 nm to 1064 nm wavelengths		
Bar Code	Part Number	Description
23241	FOP-11-11-633-4/125-P-P-40-XX-3-1	Fiber optic polarizer for 633 nm with 40dB return loss, and with 1 meter long, 3 mm OD kevlar reinforced PVC cabled 4/125 PM fiber pigtails, with no connectors.
23242	FOP-11-11-633-4/125-S-P-40-XX-3-1	Fiber optic polarizer for 633 nm with 40dB return loss, and with 1 meter long, 3 mm OD kevlar reinforced PVC cabled 4/125 singlemode fiber on the input, 4/125 PM fiber on the output, with no connectors.
23243	FOP-11-11-633-4/125-S-S-40-XX-3-1	Fiber optic polarizer for 633 nm with 40dB return loss, and with 1 meter long, 3 mm OD kevlar reinforced PVC cabled 4/125 singlemode fiber pigtails, with no connectors.
23244	FOP-11-11-800-5/125-P-P-40-XX-3-1	Fiber optic polarizer for 800 nm with 40dB return loss, and with 1 meter long, 3 mm OD kevlar reinforced PVC cabled 5/125 PM fiber pigtails, with no connectors.
23245	FOP-11-11-800-5/125-S-P-40-XX-3-1	Fiber optic polarizer for 800 nm with 40dB return loss, and with 1 meter long, 3 mm OD kevlar reinforced PVC cabled 5/125 singlemode fiber on the input, 5/125 PM fiber on the output, with no connectors.
23246	FOP-11-11-800-5/125-S-S-40-XX-3-1	Fiber optic polarizer for 800 nm with 40dB return loss, and with 1 meter long, 3 mm OD kevlar reinforced PVC cabled 5/125 singlemode fiber pigtails, with no connectors.
14321	FOP-11-11-980-6/125-P-P-40-XX-3-1	Fiber optic polarizer for 980 nm with 40dB return loss, and with 1 meter long, 3 mm OD kevlar reinforced PVC cabled 6/125 PM fiber pigtails, with no connectors.
23247	FOP-11-11-980-6/125-S-P-40-XX-3-1	Fiber optic polarizer for 980 nm with 40dB return loss, and with 1 meter long, 3 mm OD kevlar reinforced PVC cabled 6/125 singlemode fiber on the input, 6/125 PM fiber on the output, with no connectors.
23248	FOP-11-11-980-6/125-S-S-40-XX-3-1	Fiber optic polarizer for 980 nm with 40dB return loss, and with 1 meter long, 3 mm OD kevlar reinforced PVC cabled 6/125 singlemode fiber pigtails, with no connectors.
23249	FOP-11-11-1064-6/125-P-P-40-XX-3-1	Fiber optic polarizer for 1064 nm with 40dB return loss, and with 1 meter long, 3 mm OD kevlar reinforced PVC cabled 6/125 PM fiber pigtails, with no connectors.
23250	FOP-11-11-1064-6/125-S-P-40-XX-3-1	Fiber optic polarizer for 1064 nm with 40dB return loss, and with 1 meter long, 3 mm OD kevlar reinforced PVC cabled 6/125 singlemode fiber on the input, 6/125 PM fiber on the output, with no connectors.
23251	FOP-11-11-1064-6/125-S-S-40-XX-3-1	Fiber optic polarizer for 1064 nm with 40dB return loss, and with 1 meter long, 3 mm OD kevlar reinforced PVC cabled 6/125 singlemode fiber pigtails, with no connectors.

Standard Parts (continued)

Miniature Polarizers

Bar Code	Part Number	Description
23262	FOP-21-11-1550-8/125-P-P-60-XX-1-1	Miniature fiber optic polarizer for 1550 nm with 60dB return loss, and with 1 meter long, 0.9 mm OD loose tube cabled 8/125 PM fiber pigtails, with no connectors.
23263	FOP-21-11-1550-9/125-S-P-60-XX-1-1	Miniature fiber optic polarizer for 1550 nm with 60dB return loss, and with 1 meter long, 0.9 mm OD jacketed Corning SMF-28 singlemode fiber on the input, 8/125 PM fiber on the output, with no connectors.
23264	FOP-21-11-1550-9/125-S-S-60-XX-1-1	Miniature fiber optic polarizer for 1550 nm with 60dB return loss, and with 1 meter long, 0.9 mm jacketed Corning SMF-28 fiber pigtails, with no connectors.

Low Cost Polarizers

Bar Code	Part Number	Description
23265	FOP-31-11-1550-8/125-P-P-40-XX-1-1	Low cost fiber optic polarizer for 1550 nm with 40dB return loss, and with 1 meter long, 0.9 mm OD loose tube cabled 8/125 PM fiber pigtails, with no connectors.
23266	FOP-31-11-1550-9/125-S-P-40-XX-1-1	Low cost fiber optic polarizer for 1550 nm with 40dB return loss, and with 1 meter long, 0.9 mm OD jacketed Corning SMF-28 singlemode fiber on the input, 8/125 PM fiber on the output, with no connectors.
23267	FOP-31-11-1550-9/125-S-S-40-XX-1-1	Low cost fiber optic polarizer for 1550 nm with 40dB return loss, and with 1 meter long, 0.9 mm jacketed Corning SMF-28 fiber pigtails, with no connectors.

Ordering Example For Standard Parts:

A customer needs a polarizer to improve the polarization extinction ratio of the light coming out of his 980 nm laser diode, which is pigtailed with polarization maintaining fiber. Connectors are not needed.

Bar Code	Part Number	Description
14321	FOP-11-11-980-6/125-P-P-40-XX-3-1	Fiber optic polarizer for 980 nm with 40dB return loss, and with 1 meter long, 3 mm OD kevlar reinforced PVC cabled 6/125 PM fiber pigtails, with no connectors.

Ordering Information

Pigtail Style:

Polarizer size:

- 1 for 12.5 mm size
- 2 for miniature 5.5 mm OD size
- 3 for low cost 4 mm OD size
- 4 for all inline polarizer

Wavelength: Specify in nanometers
(Example: 1550 for 1550 nm)

Fiber core/cladding sizes, in microns
9/125 for 1300/1550 nm SM fiber
See Tables 1 to 5 for other standard fiber sizes

Input Fiber: M = Multimode
S = Singlemode
P = Polarization maintaining

Output Fiber: M = Multimode
S = Singlemode
P = Polarization maintaining

Backreflection level: 25, 40, 50, or 60dB
60dB version available for 1300, 1550, 2000 nm wavelengths only

FOP-A1-11-W-a/b-l-O-LB-XY-JD-L

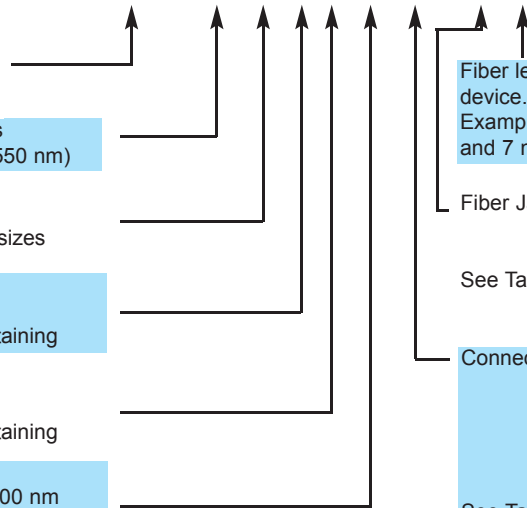

Fiber length, in meters, on each side of the device.
Example: To order 1 meter of fiber at the input and 7 meters at the output, replace L with 1,7

Fiber Jacket Type: 1 = 900 Micron OD hytrel jacket
3 = 3 mm OD Kevlar reinforced PVC cable
See Table 7 for other jacket sizes

Connector Code: 3S = Super NTT-FC/PC
3U = Ultra NTT-FC/PC
3A = Angled NTT-FC/PC
8 = AT&T-ST
SC = SC
SCA = Angled SC
See Table 6 for other connectors

NOTE: For extinction ratios greater than 25dB or 30dB, add the term “-ER=25” or “-ER=30” to the end of the part number.

4

Ordering Example For Custom Parts

A customer has a tunable laser for 1520-1570 nm, pigtailed with singlemode fiber with a Super PC finish FC connector on it. She wants to polarize the signal as much as possible, and transmit it through a polarization maintaining fiber, achieving over 30dB extinction ratios. The output fiber also needs to have a Super PC finish FC connector on the end. Return losses and insertion losses are not critical.

Part Number	Description
FOP-11-11-1520/1570-9/125-S-P-40-3S3S-3-1-ER=30	Fiber optic polarizer for 1520 nm to 1570 nm, with 60dB return loss, 30dB extinction ratio, and with 1 meter long, 3 mm OD Kevlar reinforced PVC cabled Corning SMF-28 singlemode fiber on the input, 8/125 PM fiber on the output, with Super FC/PC connectors on both ends.

Application Notes

Upgrading System Output Extinction Ratio

When several PM fiber pigtailed components are connected, there is the possibility that the accumulated extinction ratio will degrade. Each time two PM fibers are joined, any offset of their stress axes can cause the extinction ratio to get a little lower. For example, two 30dB fibers offset by 3 degrees can have a net extinction ratio of only 25dB. Add a couple more interfaces with similar angles and the value gets even worse. In order to have the final output extinction ratio be high, one can insert a pigtailed polarizer as the least component. This can drastically improve the output extinction ratio of the system with only a minor impact on system loss. For example, upgrading from a 15dB ER signal to a 25dB ER signal would only incur 0.125dB loss (plus device loss). A small price to pay for a 10dB ER gain.

Basic equation is $\text{Log}(1 - (\text{inv log original ER} - \text{inv log new ER}))$

Ex 15dB upgraded to 25dB is 0.125dB loss (plus device loss)

Frequently Asked Questions (FAQs)

- Q.** Why is my output power so low?
 - A.** Check orientation and/or state of input polarization. If input fiber is PM, check to make sure light is launched along the correct axis.
- Q.** Why is output extinction ratio low?
 - A.** Check you are using it in correct direction. Polarizer alignment is optimized to the output fiber for best output extinction ratio. The input fiber is oriented for transmission. These two placements are very similar, but may be slightly different.
- Q.** Why is my output power fluctuating?
 - A.** Check stability of input fiber and polarization states. If there are large backreflections coming from further down the fiber optic system, an isolator may be required to protect the source or defeat an etalon effect.