



OZ Optics

www.ozoptics.com

219 Westbrook Rd, Ottawa, ON, Canada, K0A 1L0 Toll Free: 1-800-361-5415 Tel:(613) 831-0981 Fax:(613) 836-5089 E-mail: sales@ozoptics.com

DIRECTIONAL OPTICAL TAPS AND MONITORS

(PATENT: CANADA 2,494,133, USA 7095931, 7295731 AND CHINA ZL03818458.3)

Features:

- Low cost
- Miniature size package
- Continuous fiber. No interruptions to optical path
- Remotely or locally controllable
- RS232 or USB communication options
- High directivity, Large dynamic range
- Low insertion loss, return loss, and polarization return loss
- Wavelength insensitive response
- High power handling
- Specialty fibers and Polarization Maintaining (PM) fiber versions available
- High extinction ratios for PM versions
- Versions for any wavelength from 460nm - 1700nm available
- Available with or without a photodiode
- Can be integrated within other optical components using automated processes
- Multiple channel version available
- Tested under GR-468 for InGaAs 3 PIN type

Applications:

- Optical power control devices
- Channel balancing for Wavelength Division Multiplexing (WDM) systems
- Dynamic optical amplifier gain monitoring
- Power monitoring
- FTTH Network monitoring
- Real time in-line test and measurement
- Fiber optic sensors

Product Description:

OZ Optics now offers a new series of inline optical power monitor and tap couplers based on a revolutionary, patented technology. These taps and monitors provide a way to easily measure the signal intensity through an optical fiber in a simple, miniature package. They are ideal to use with optical amplifiers or DWDM systems for real time monitoring and feedback, or for fiber optic sensors.

Competing monitoring systems typically use fused couplers to tap a fixed amount of light into another fiber and to a photodiode. This method is bulky and must be done using discrete components. In contrast, OZ Optics' optical taps direct a controlled amount of light from the fiber core to the surface where it can be directly monitored. This is all done without bending, shaping, or otherwise harming the fiber. As a result the tap can be directly incorporated into optical assemblies, without affecting functionality.

Taps can be made into standard singlemode fiber, polarization maintaining (PM) fibers, or specialty fibers, for any design wavelength. Different tap ratios are available on request. The taps are directional in nature, tapping light traveling in one direction through the fiber, but not in the reverse direction. This directionality is ideal for monitoring traffic in one direction independently of signals travelling in the other direction. It can also be used for measuring return losses instead of transmitted power. Bi-directional versions can be provided on request.

Optical power monitors combine the optical tap design with a photodiode in a single package. The device produces a current proportional to the optical power within the fiber. The small size and simple interface makes it very easy to design into optical hardware.

Optical taps and monitors are available in different configurations. Single channel optical taps are immediately available, either with or without photodiodes. Devices can be made for as little as \$5USD for 10,000 piece orders, not including the photodetectors. Multiple channel power monitors for WDM applications will be available shortly. Volume pricing as low as \$20 USD per channel will be offered for 10,000 piece orders. Please note that the photodiode cost is the limiting factor in the cost. OZ Optics can provide taps with germanium photodiodes to lower costs, provided one can accept a lower dynamic range. Contact OZ Optics for further details.

Taps can be directly integrated onto fiber pigtail assemblies and packaged inside devices that rely on optical feedback. For instance laser diodes can be built with inline optical taps directly inside the package to monitor the output signal intensity. This provides a more precise means of monitoring the signal intensity, as signals seen by the directional tap are not influenced by return losses from the fiber output, which otherwise would be seen in conventional laser diode modules. This allows the main device and the monitor photodiode to be packaged into a single housing, reducing both size and costs. To the best of our knowledge, this is the only technology available to make this possible. A novel patented manufacturing process allows full automation, sharply reducing costs.

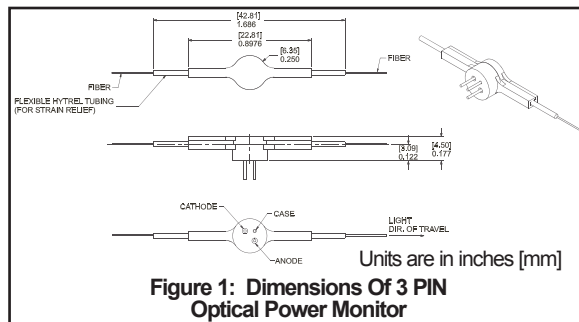
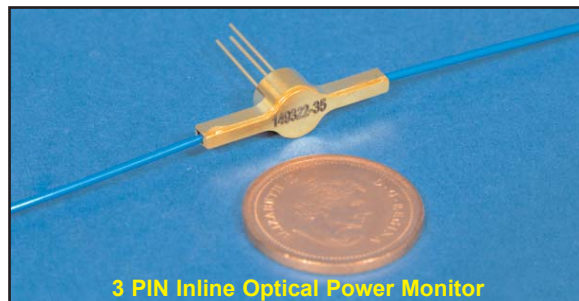
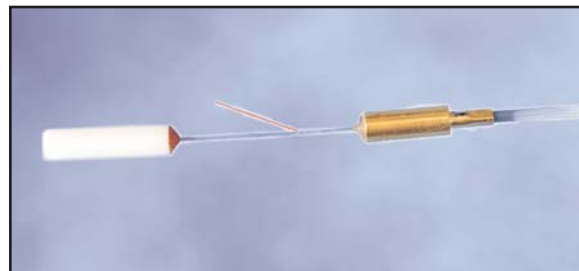

Figure 1: Dimensions Of 3 PIN Optical Power Monitor



OZ Optics is licensing this unique technology to passive and active optical component manufacturers and providing the equipment, training and service for incorporating inline taps into new and existing products. Applications include laser diodes, modulators, attenuators, MEMS systems, and others. The unit cost of each optical tap/power monitor can be as little as pennies, depending on the manufacturing volume. The process can also be used to produce inline attenuators, to precisely trim the output power from a device or subsystem. Contact OZ Optics for additional information and licensing terms.

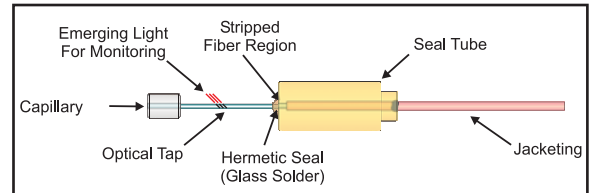

Figure 3: Hermetic Patchcord With Built-In Optical Tap

Inline optical taps possess several key advantages over the standard technique of using a fused coupler with a photodiode for power monitoring. These include:

- **Size:** Fused splitters are typically at least 30mm long, plus you need tens of centimeters of fiber on the arms of the splitters for attaching the splitter to your device and to the photodiode. In contrast, inline taps can be made within a package less than a centimeter in length.
- **Consolidation:** Inline taps combine the functions of a fused splitter and a photodiode into one package.
- **Integration:** Unlike fused coupler systems, inline taps can be built within a device at the component level, thus simplifying overall system designs.
- **Automation:** Inline optical taps can be made in a single automated process. In contrast adding fused splitters with photodiodes require several discrete processes, with some manual operations necessary.
- **Flexibility:** Inline optical taps can be made with tap ratios as small as 0.1%, allowing one to manufacture optical taps for very high power applications
- **Multichannel Friendly:** Multichannel Inline optical taps are manufactured in a small, easy to use package. In contrast assembling multichannel monitors with fused splitters makes a cumbersome package with many fibers to arrange.

Standard Product Specifications:

Optical Properties of Taps Without Photodiodes ¹

Operating Wavelength	1450-1650nm, or 1280-1440nm standard.
Tap Ratio	1% ± 0.5% standard ² , tighter tap ratio available upon request.
Tap Efficiency ³	>60%
Insertion Loss	<0.1dB ⁴
Return Loss	>70dB (excluding connectors)
Directionality	> 30dB ⁵
Polarization Dependent Loss	<0.1dB (over 1528-1565nm wavelength range)
Polarization Dependent Response ⁵	<0.2dB (over 1528-1565nm wavelength range)
Wavelength Dependent Response ⁵	<0.25dB (over 1528-1565nm wavelength range)
Polarization Extinction Ratio ⁶	>20dB (>30dB extinction ratios available on request)
Temperature Dependent Responsivity ⁷	< 0.25dB (over 1528-1565nm wavelength range)
Power Handling	Over 1 Watt ⁸

Photodiode Properties

Detector Type	PIN InGaAs	Silicon
Wavelength Range	900-1700nm	320-1060nm
Input Power Range ⁹	-28 to +30dBm	-30 to +27dBm
Dark Current	1 nA at 5V reverse voltage	1 nA at 5V reverse voltage
Responsivity ¹⁰	~9mA/W at 1550nm	~ 5mA/W at 780nm
Frequency Response (3dB roll off, with R _L = 50Ω)	200 MHz @ 5V reverse bias	500 MHz @ 10V reverse bias
Maximum Reverse Voltage	20V	20V

Environmental

Operating Temperature	-5 to 75°C	0 to 70°C
Storage Temperature	-40 to 85°C	
Relative Humidity	< 85% RH noncondensing at 85°C	
Dimensions	See Figure 1	

¹ As measured using Corning SMF-28 fiber or 1550nm PANDA style polarization maintaining fiber. Other fiber types available on request.

² Other tap ratios, from 0.1% to over 5% are available on request.

³ Defined as (Power received at the detector)/(Power attenuated by the tap)*100%

⁴ For 1% taps or lower.

⁵ As measured from a 1% tap mated with an InGaAs detector, with index matching epoxy.

⁶ PM fiber versions only.

⁷ For the InGaAs-TO18 version

⁸ While not yet tested at powers higher than 1 watt, the units are expected to handle in excess of 2 watts of power under special biasing condition and for tap ratio <0.5%, with also proper TE cooling and heat sinking.

⁹ When used with a 1% tap, with reverse bias for highpower end.

¹⁰ Ratio between the photodiode current versus the optical power through the fiber when used with a 1% tap.

Ordering Information For Standard Parts:

Bar Code	Part Number	Description
37368	OPM-11-1550-9/125-S-XX-1-1-1-INGAAS-TO18	Single channel singlemode optical power monitor for 1450-1650nm wavelengths, with a 1% tap ratio, and using a PIN InGaAs detector in a 3pin TO-18 can. The fiber on either side of the monitor is 1 meter long, 1mm loose tube jacketed, with no connectors.
13649	OPM-11-1550-9/125-S-XX-1-1-1-INGAAS	Single channel singlemode optical power monitor for 1450-1650nm wavelengths, with a 1% tap ratio, and using a PIN InGaAs detector. The fiber on either side of the monitor is 1 meter long, 1mm loose tube jacketed, with no connectors.
16241	OPM-11-1550-8/125-P-XX-1-1-1-INGAAS	Single channel PM optical power monitor for 1450-1650nm wavelengths, with a 1% tap ratio, and using a PIN InGaAs detector. The fiber on either side of the monitor is 1 meter long, 1mm jacketed, with no connectors.
13650	OPM-11-1300-7/125-P-XX-1-1-1-INGAAS	Single channel PM optical power monitor for 1280-1440nm wavelengths, with a 1% tap ratio, and using a PIN InGaAs detector. The fiber on either side of the monitor is 1 meter long, 1mm jacketed, with no connectors.

Ordering Examples For Standard Parts:

A customer needs to monitor the signal power from a polarization maintaining fiber before an optical amplifier. The customer will fusion splice an inline power monitor into his system. The signal wavelength is from 1520 to 1570 nm. The OZ Optics bar code number and description of the power monitor for this application is as follows:

Bar Code	Part Number	Description
23841	OPM-11-1550-8/125-P-XX-1-2-3-INGAAS	Single channel PM optical power monitor for 1450-1650nm wavelengths, with a 3% tap ratio and using a PIN InGaAs detector. The fiber on either side of the monitor is 1 meter long, 1mm jacketed, and with no connectors.

Ordering Information For Custom Parts:

OZ Optics welcomes the opportunity to provide custom designed products to meet your application needs. As with most manufacturers, customized products do take additional effort so please expect some differences in the pricing compared to our standard parts list. In particular, we will need additional time to prepare a comprehensive quotation, and lead times will be longer than normal. In most cases non-recurring engineering (NRE) charges, lot charges, and a 25 piece minimum order will be necessary. These points will be carefully explained in your quotation, so your decision will be as well-informed as possible. We strongly recommend buying our standard products.

Questionnaire For Custom Parts:

1. What is your operating wavelength range?
2. Are you using standard singlemode, polarization maintaining, or a speciality fiber? What type?
3. What is the expected optical power through the fiber?
4. Do you need a single channel, or multiple channel device?
5. What sort of tap ratio do you require?
6. Do you need a detector? What type?
7. Do you need the ends of the fiber connectorized? What type of connector do you need?
8. How long should each end of the fiber be?
9. Do you need the fiber cabled? What cable size do you need?

Description

Single or Multi-Channel Inline Optical Power Monitor

Part Number
OPM-1N-W-a/b-F-XY-JD-L-TR-DET

N = Number of fibers (1 channel is standard)

W = Wavelength in nm:
 1550 for 1450 to 1650nm operating range
 1300 for 1280 to 1440nm operating range

a/b = Fiber core/cladding sizes, in microns:
 9/125 for 1300 or 1550nm SMF
 7/125 for 1300nm PMF
 8/125 for 1550nm PMF.
 See Tables 1 to 5 of the OZ Optics Standard Tables for other fiber sizes

F = Fiber type: S = Singlemode
 P = Polarization maintaining

DET = Detector type:
 INGAAS-TO18 for a 3 PIN InGaAs detector
 INGAAS for a PIN InGaAs detector
 SI for a silicon detector
 X for a bare tap only, no detector or housing

TR = Tap ratio, in percent
 1% is standard

L = Fiber length, in meters, on each side of the device.

JD = Fiber jacket type:
 0.25 = 250 micron acrylate coating
 0.4 = 400 micron acrylate coating
 1 = 900 micron OD hytrel jacket

XY = Input and output connector codes
 3S = Super NTT-FC/PC
 3U = Ultra NTT-FC/PC
 3A = Angled NTT-FC/PC
 SCU = Ultra SC
 SCA = Angled SC
 LC = LC
 X = No Connector

Ordering Examples For Custom Parts:

A 4 channel PM power monitor is required with an operating wavelength of 1520 to 1570 nm. The standard 1% tap ratio with a PIN InGaAs detector is sufficient for the application. For each channel the input end will be unterminated, while the output end will have a male angled FC connector. 1mm OD loose tube cabling is required. Fiber length for all fibers will be 0.5 m on each side.

Part Number	Description
OPM-14-1550-8/125-P-X3A-1-0.5-1-INGAAS	Four channel PM optical power monitor for 1450-1650nm wavelengths, with a 1% tap ratio and a PIN InGaAs detector. The fiber on either side of the monitor is 0.5 meter long, 1mm jacketed, with no connector on the input, FC/APC connector on the output.

Application Notes:

Unidirectional Versus Bi-Directional Taps and Power Monitors: Because of the directional nature of standard optical taps and monitors, one normally will measure light traveling in one direction through the fiber, but not in the reverse direction. This directionality is ideal for monitoring traffic in one direction independently of the other direction. For instance, by using two optical taps in opposing directions, one can measure output power and return losses through a system simultaneously.

In some cases one may prefer having a bi-directional tap or monitor. Such devices can be produced on request. These devices are essentially two optical taps back to back, designed so that the tapped light is incident at one point along the fiber.

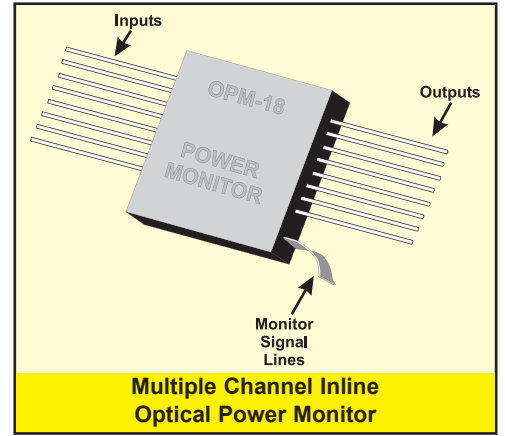

Application Examples:

Example #1: Optical power stabilization of an optical amplifier: The output signal from an optical amplifier is affected by several factors, including pump energy polarization dependent losses or gain, and the signal intensity of the source. By using an optical power monitor together with a variable attenuator, one can control the signal intensity to ensure that the optical output power remains constant.

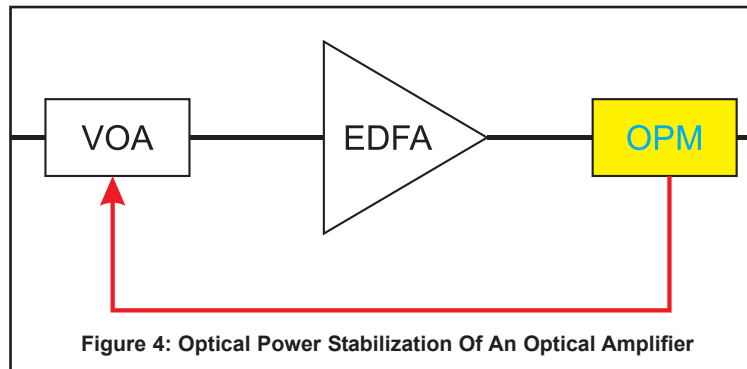

Figure 4: Optical Power Stabilization Of An Optical Amplifier

Example #2: Laser diode with integrated power monitor: Laser diodes can be built with inline optical taps directly inside the package to monitor the output signal intensity. This provides a more precise means of monitoring the signal intensity, as signal seen by the directional tap is not influenced by return losses from the fiber output, which otherwise would be seen in conventional laser diode modules.

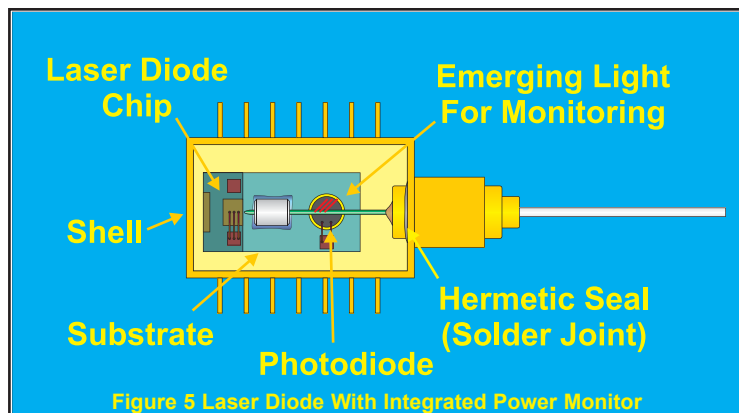

Figure 5 Laser Diode With Integrated Power Monitor

Example 2: Using Smart patchcords to monitor a FTTH network.

These days fibers are being employed in fiber to the home (FTTH) networks. Such networks may use a single wavelength source, or multiplex several wavelengths, such as 1310nm, 1480nm and 1550nm, to transmit data. Each network may have several dozen nodes on it. Often the optical signal strength through these networks must be measured at each node, to monitor signal quality and troubleshoot connection problems. However, problems may occur while the repair technician is checking the signals.

Typically to measure the optical strength at a node, the technician has to break the connection, shutting down the node. He then has to measure the relative signal strengths. If there are multiple wavelengths going through the same node, then he needs to use an optical spectrum analyzer (OSA) or wavemeter, which is costly. Finally, there is a risk of contaminating the fiber ends while

disconnecting or reconnecting the node to the network. This can lead to problems later on, and possible costly repairs. Therefore these measurements can be quite costly.

In contrast, smart patchcords can be built onto the fiber of each node and installed at a convenient location, such as a patch panel. The smart patchcords tap about 1% of the light out and can be designed to receive light only for a specific wavelength. Thus three units could be used to three separate wavelengths at each node, without interrupting transmission. Smart patchcords can be provided with optional electronics and RS232 or USB connections, allowing the technician to simply connect the unit to a laptop or PDA to record and log the measurements effortlessly. Alternatively the smart patchcords could transmit their measurements on a regular basis to a remote monitoring station. Depending on the options selected, smart patchcords could be installed on every node of a network for a few tens of dollars each.

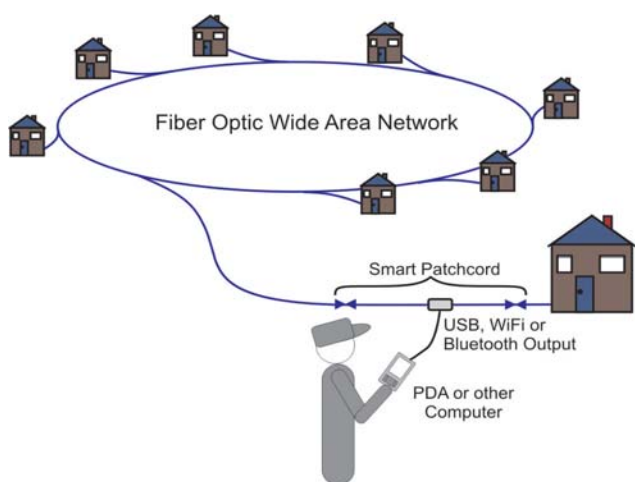

Figure 1: Testing Networks with Smart Patchcords Installed

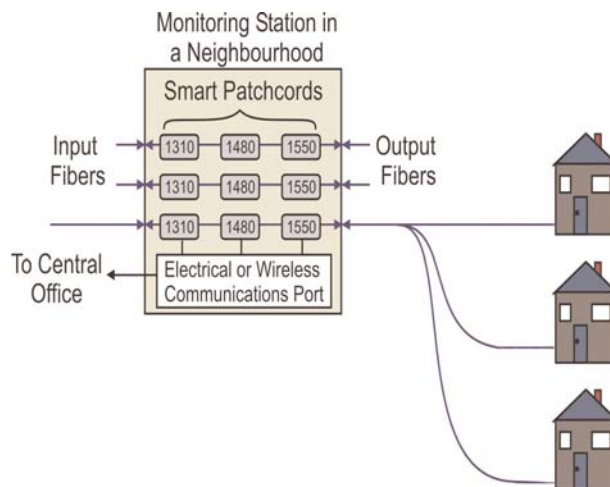

Figure 2: Remote Monitoring a WDM Network

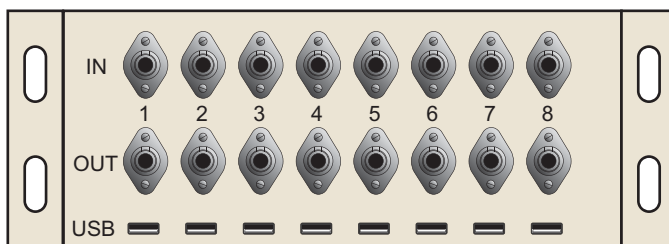

Figure 3: Smart Patchcord Patch Panel for Monitoring a Network